



1.8

Audient!

iD22

iD22

iD22

Audient ()

iD22

ADAT -

10

(10

ASP880

12

, iD22

(USB2.0)

• 2 ,6

24 /96

• 2

A

JFET.

•

•

• 4

•

•

USB2.0 c

DSP-



		1	-	27
iD22		2	/	27
		3		27
		5	Talkback	27
	:	6		27
		6		27
		6	Talkback	28
MAC OSX		6		
	USB	7		29
	MIDI (OSX)	7		29
Windows		8		29
		10		
		11		30
		11	- DSP-	31
		11		32
		12		
		12	Pro Tools	33
		13	Logic Pro	34
		14	Cubase/Nuendo	36
		15	Ableton Live	38
		16		
		17		
	/	18		39
		19		41
		20		42
	Kensington	20		43
		21		
		22		44
iD-		22		45
		22		46
		22		
		23		
		24		
		24		
		25		
		25		
		25		
		26		

iD22

:

- iD22
- 12
- USB Type A-to-B

www.audient.com/products/iD22



() ,
()

12 ()

iD22

iD22,

!



Actual PSU & USB cable may differ from images.

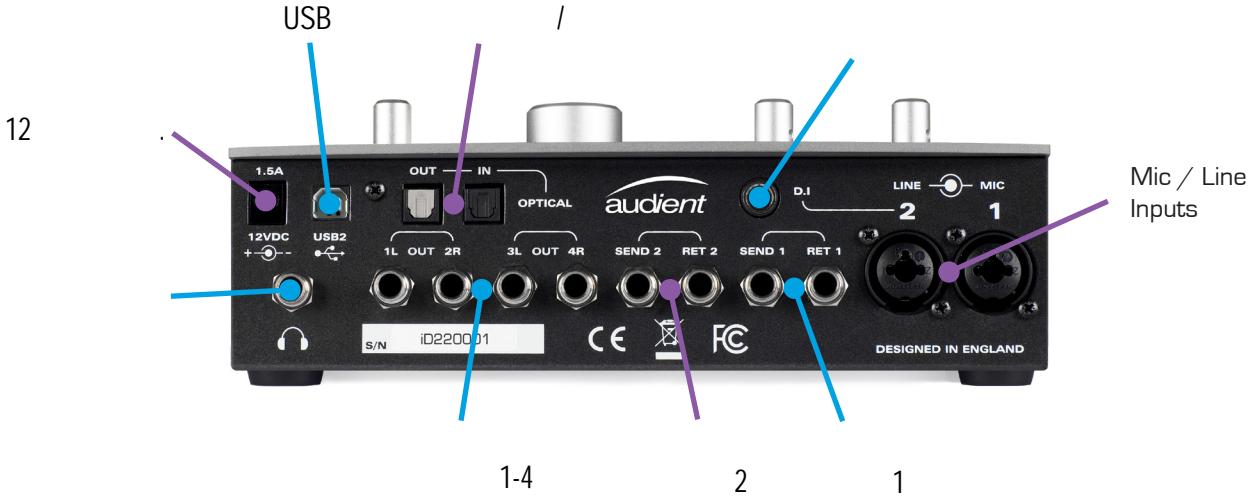
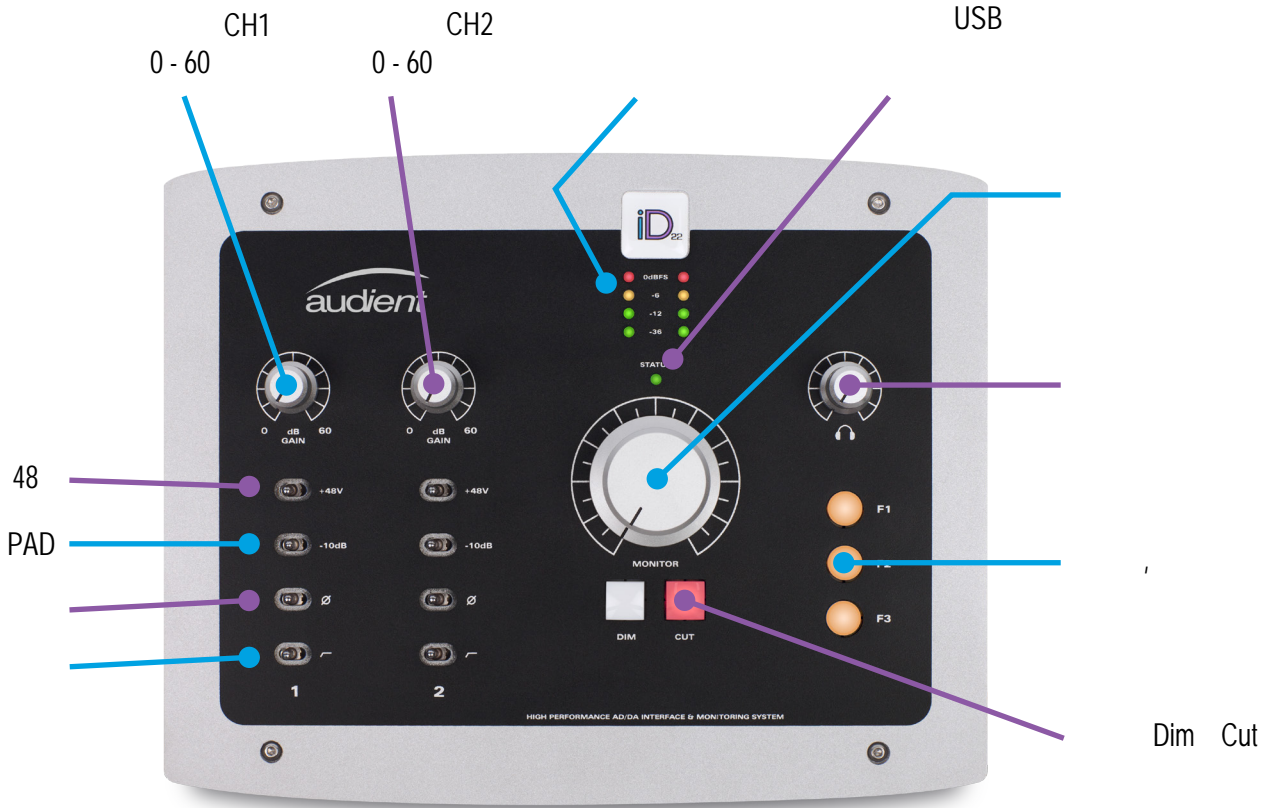

iD22,

12 .

iD22

Audient,

www.audient.com/support

iD22

1,5
264

(.2 , 24).
47-63 .

90



15B

FCC ()

15

FCC ()

).

1. -
- 2.
- 3.
- 4.



Audient Ltd,
Herriard, Hampshire, RG25 2PN, UK,
iD22

15

FCC.

Aspect House,

- 1.
- 2.



Audient Ltd

CE

iD22,



2002/95 / EC

Audient Ltd

(RoHS).

- OS X: 10.6.8 (Snow Leopard)
- Mac: Intel, .1

1.

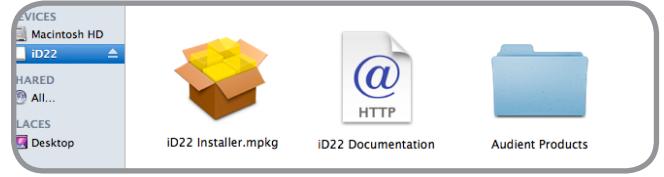

- iD- :

www.audient.com/products/downloads/iD22

2.

iD22

iD22

USB
iD22

USB

iD22

12

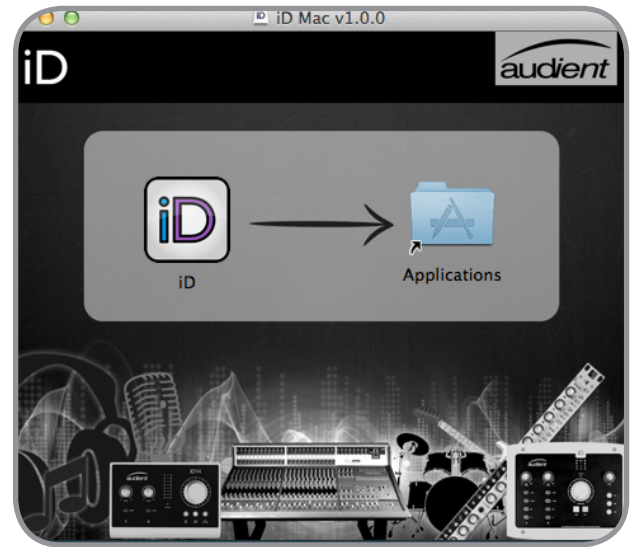

3.

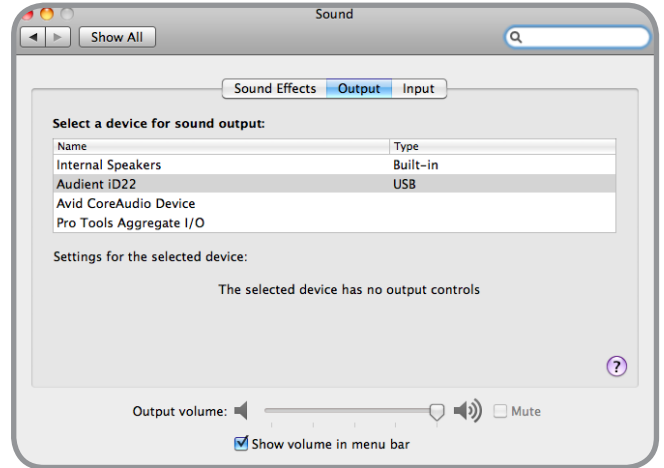

iD-

(MIDI), Audio MIDI Setup
 Applications () > Utilities () Mac HD >

Window > Show Audio Window

4.

Macintosh HD > Applications >
 System Preferences

iD22 10
 14
 Audient Internal Clock
 (),
 ()

iD22

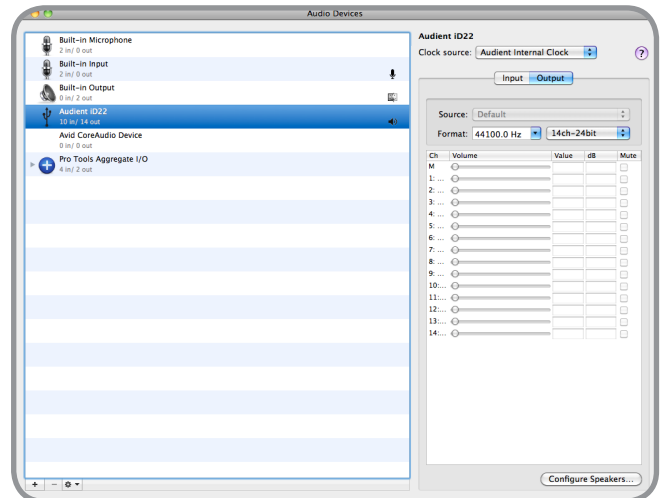

iD22

• Windows 7 (32 64)

• 2006
Intel Core 2 AMD 1,6

• .1

1.

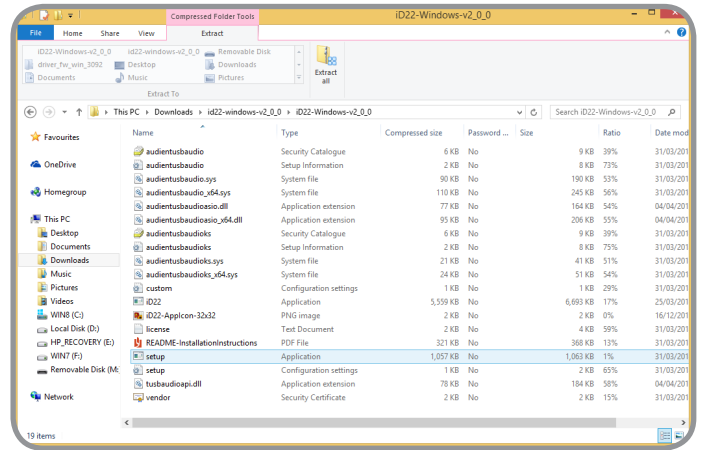

iD- :

www.audient.com/products/downloads/iD22

	iD22-Applcon-32x...	PNG image	2 KB
	license	Text Document	2 KB
	README-Installati...	PDF File	321 KB
	setup	Application	1,057 KB
	setup	Configuration settings	1 KB
	tusbaudioapi.dll	Application extension	78 KB

2. iD22

USB

iD22 USB

iD22 12

3. iD22

setup.exe

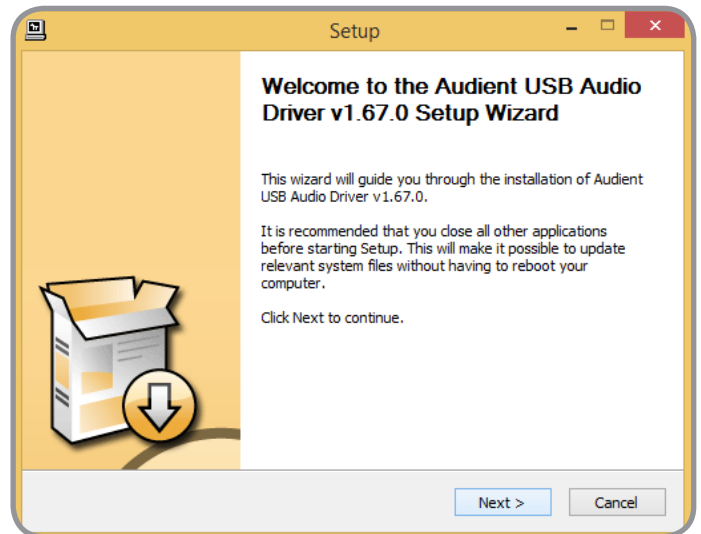

4.



iD22

STATUS

PC Settings > Control Panel > Hardware and Sound > Sound

iD22,

iD

iD

iD22

2

iD22.

Minimum	1
Low	2
Standard	4
Relaxed	8
Safe	16
Extra Safe	32

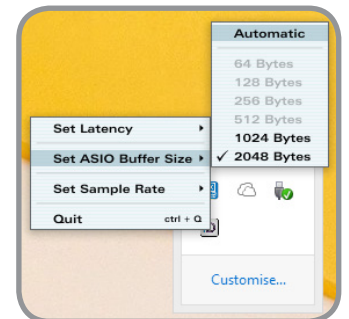
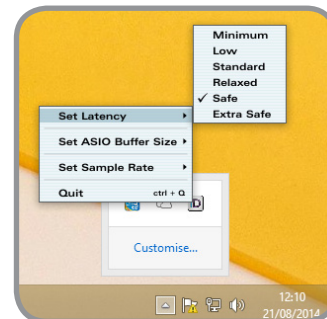
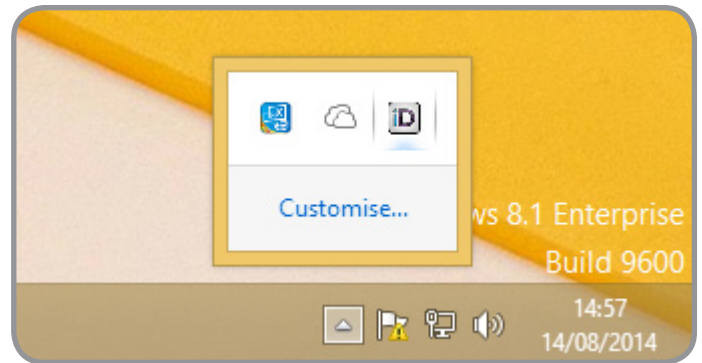
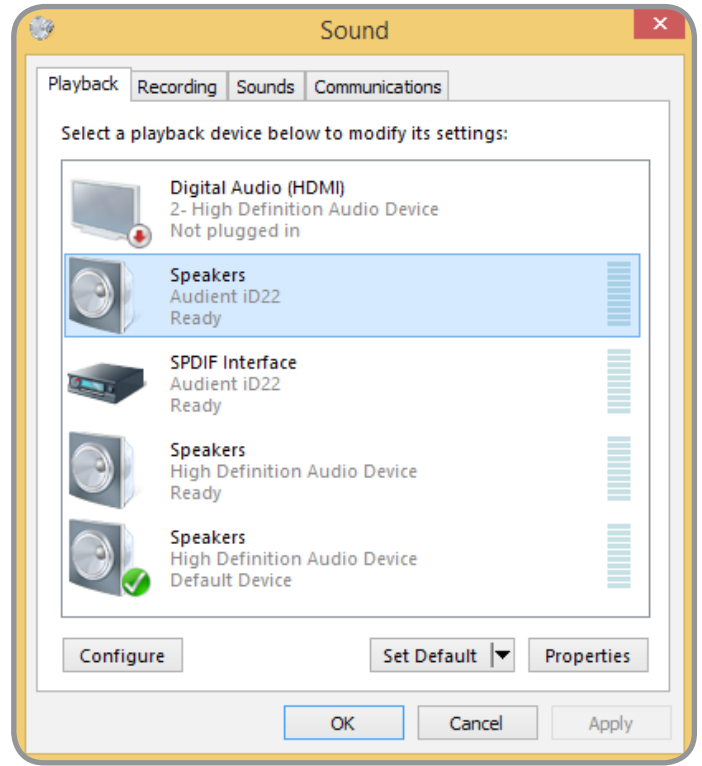

iD-

iD-



Macintosh HD > Applications > iD
Start > All Programs > Audient > iD

iD-

22



next ()
update

iD22

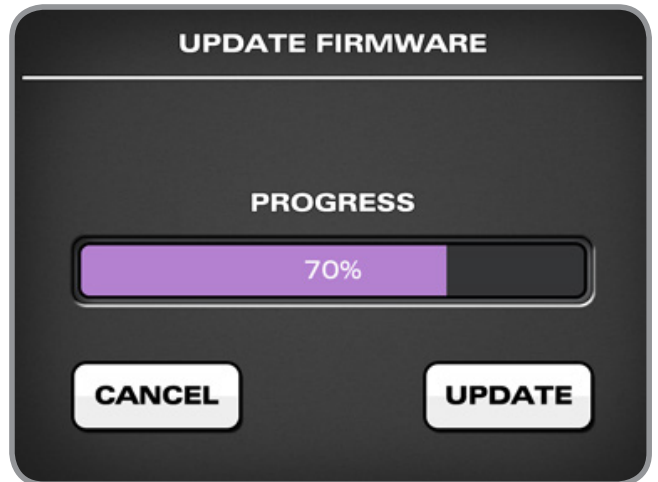

iD-

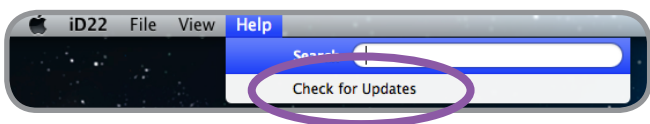

iD22

Audient.

A

8

iD22

+15 (30)

• 60

• 48 10 /

• >3 ,

• -10

• ()

• (12 / 100)

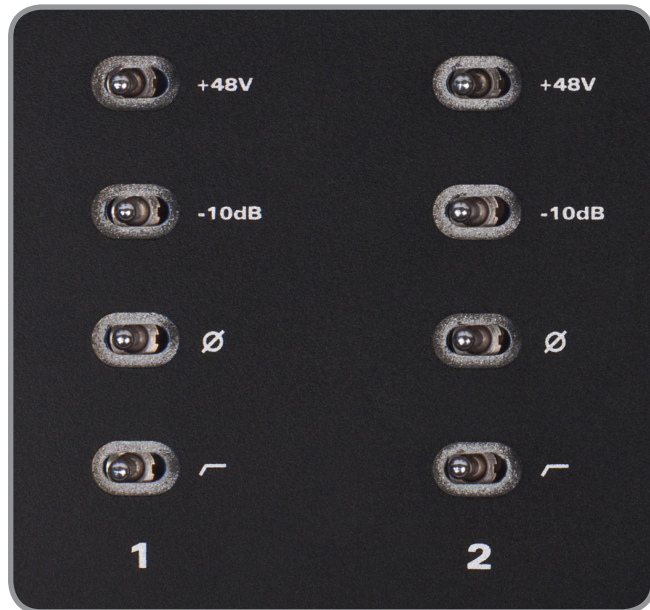

Neutrik XLR/TRS.



2 iD22
JFET
(DI-).

(TS)

(Insert).

(Send)

-10 (

),

(

-)

(

).

iD22

iD22



iD22

iD22

()

iD22.

: 0dBFS = +18dBu

iD22,

(send)

()

3+4

(ret) =

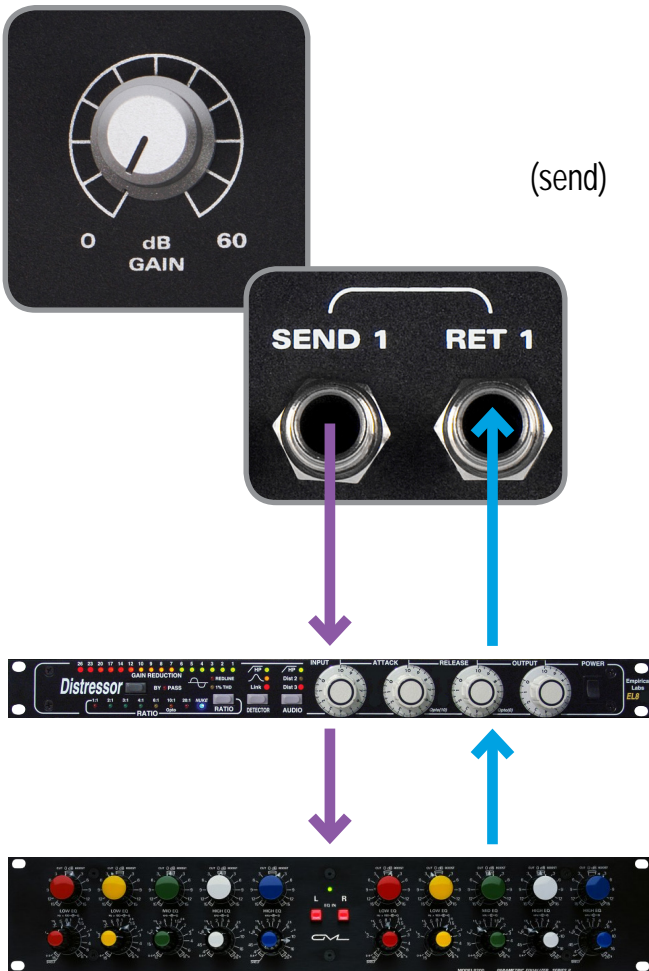

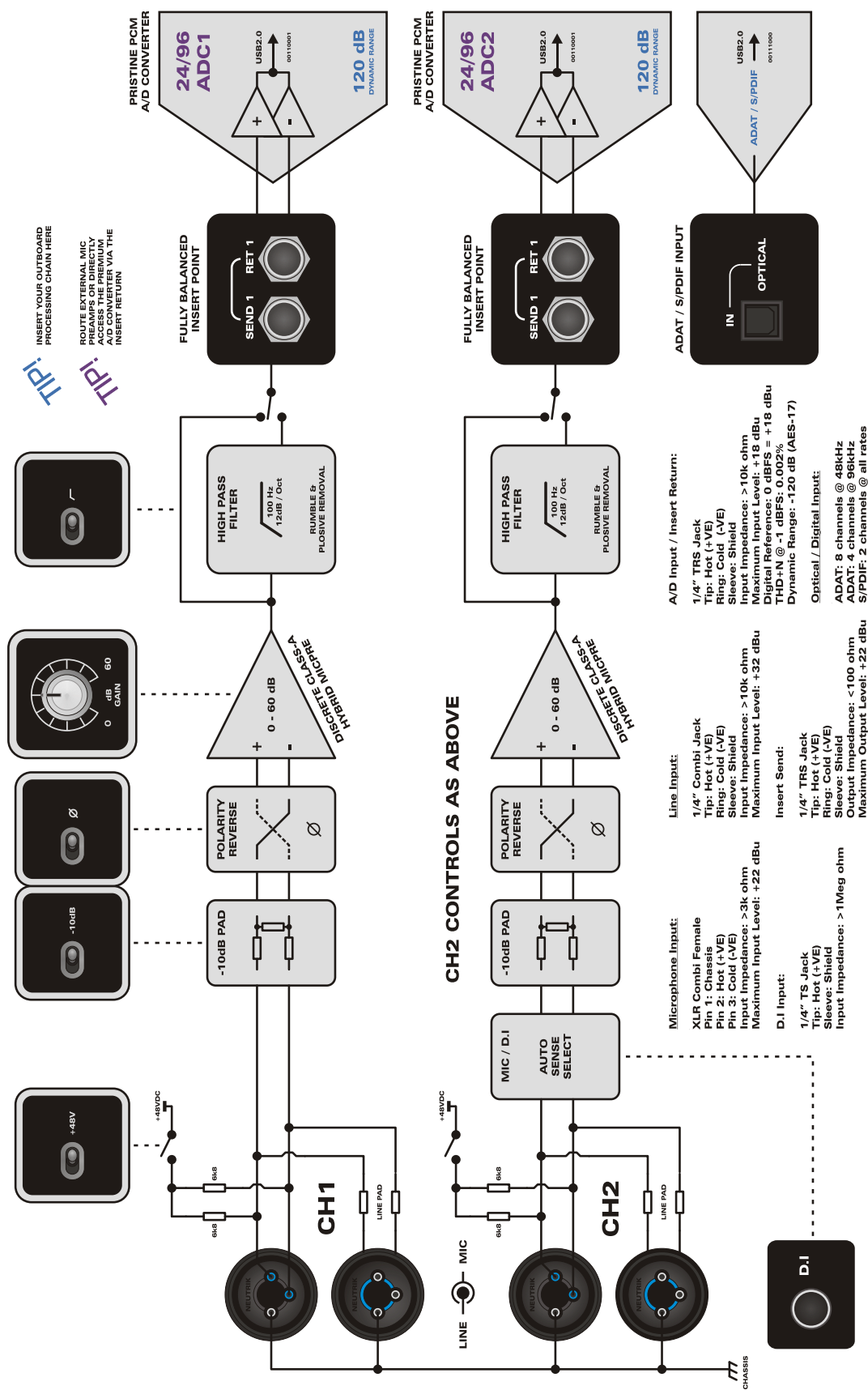

Class-A Mic Preamp, Inserts, A/D Converter & Optical Input Block Diagram

iD22 4 / 1+2
 (Main Mix),
 iD- (27). 3+4 (Cue B),
 DSP
 (), iD22 (5+6)
 DAW (iD- (Main Mix)
 Cue A B).

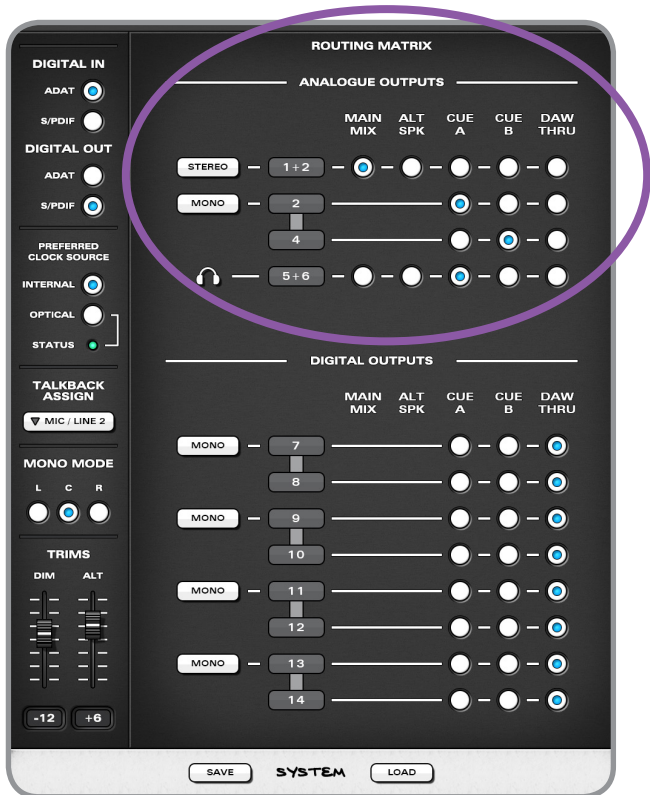

(DAW;),
 DAW Mix 3+4 5+6,
 iD-),
 1+2
 Mix (iD22). 3+4
 (5+6).

iD22

4

ASP8024.

iD22

(> 18 dBu),

< 100



iD22

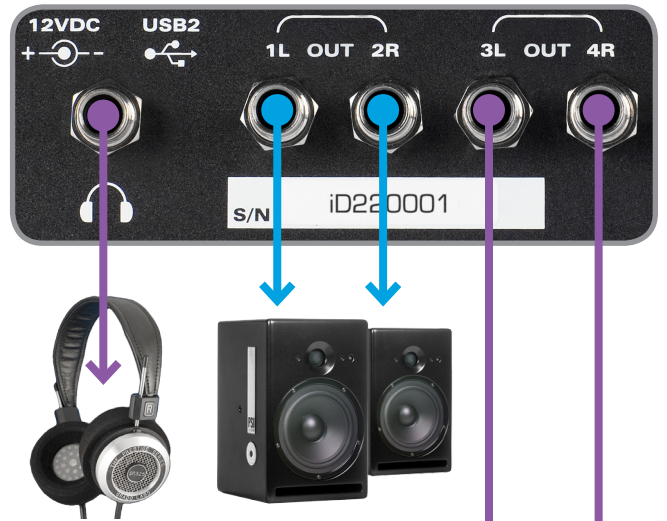

iD22

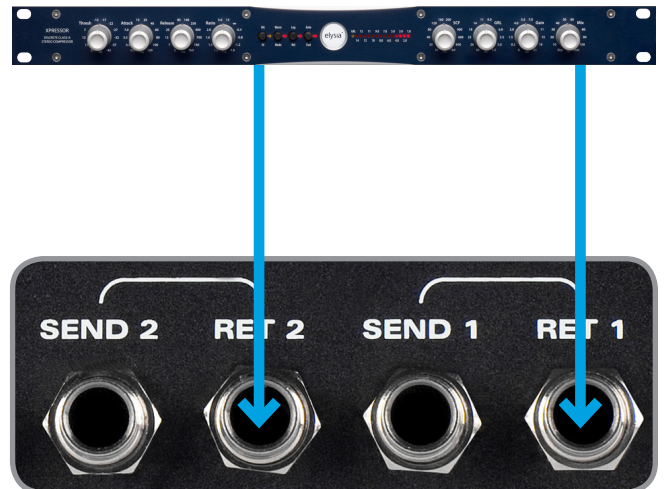
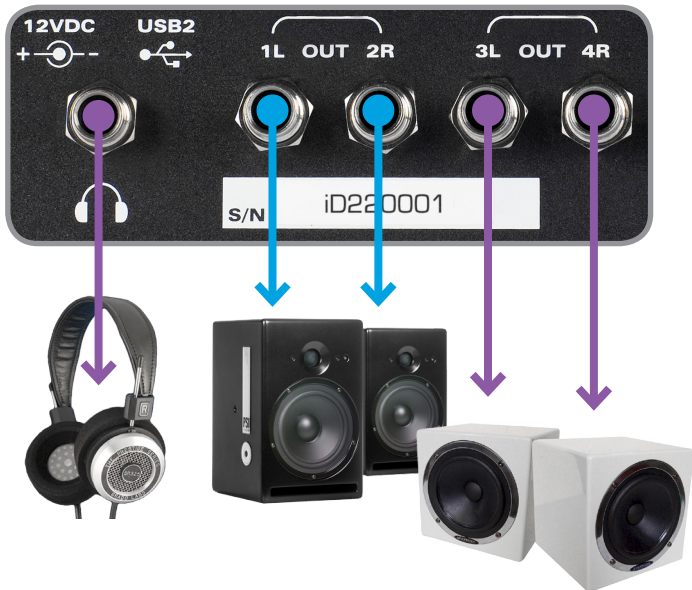

iD-

iD22

- 1+2: Cue A
- 3: Cue A
- 4: Cue B
- 5+6 Cue A

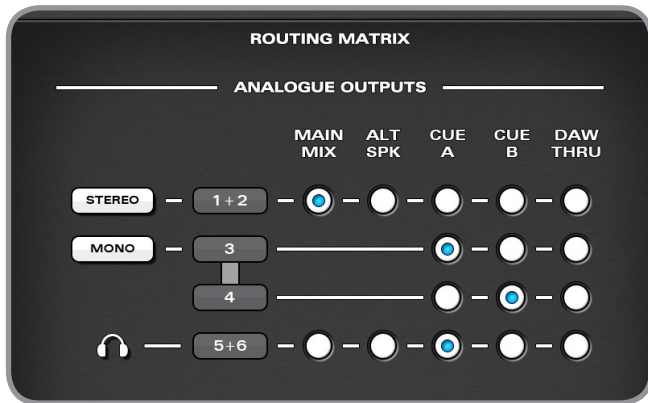

iD22

- 1+2:
- 3+4:
- 5+6

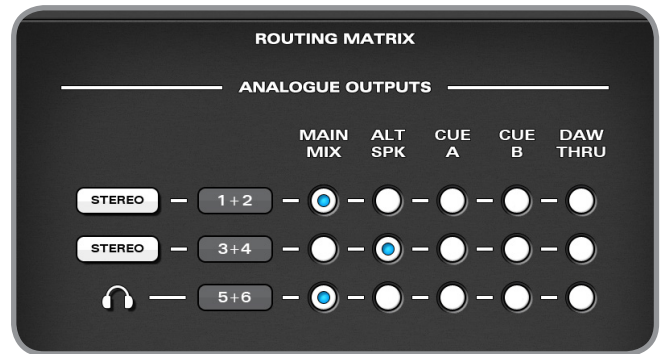

iD22

- DAW (3+4):
- 1+2: DAW ()
 - 3+4: DAW ()
 - 5+6 ()

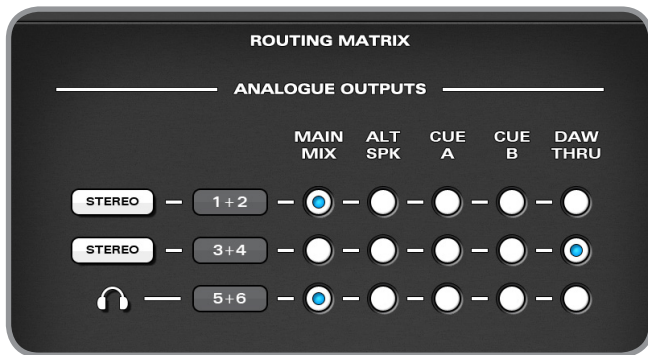

iD22

(iD-

-):
- 1+2: DAW ()
 - 3+4: DAW ()
 - 5+6

Insert Ret

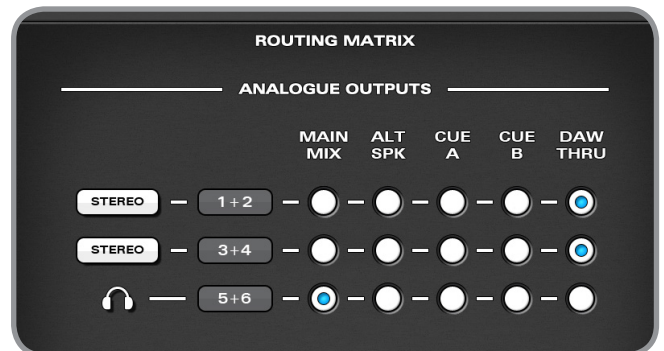

iD22

Y- ()

iD- (29)

iD22

iD-

S/PDIF

8- ADAT.

96 48

ADAT

4

S/PDIF

iD22

4

Audient MiCO
Audient,

ADAT

iD22

ASP880

10

ADAT

Hearback HUB 8-

iD22

27 33

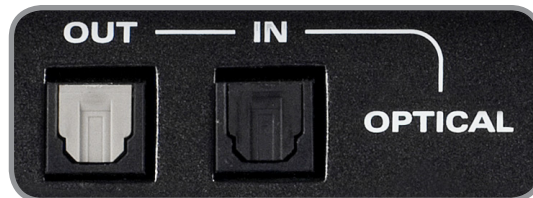

iD22

MONITOR

- ("F").
- DIM - ("F").
- CUT - ("F").
- ("F").
- Talkback ("F").

side (mid ())).

) CUT (DIM ()).
DIM

iD- () .

"F",

<http://blog.audient.com/post/29826572065/sumdifference>



iD22

4-

(DIM, CUT . .)

iD22

0dBu = -18dBFS,
+18 dBu = 0dBFS.

Kensington

DAW,
iD22

iD-

iD22



USB

7.



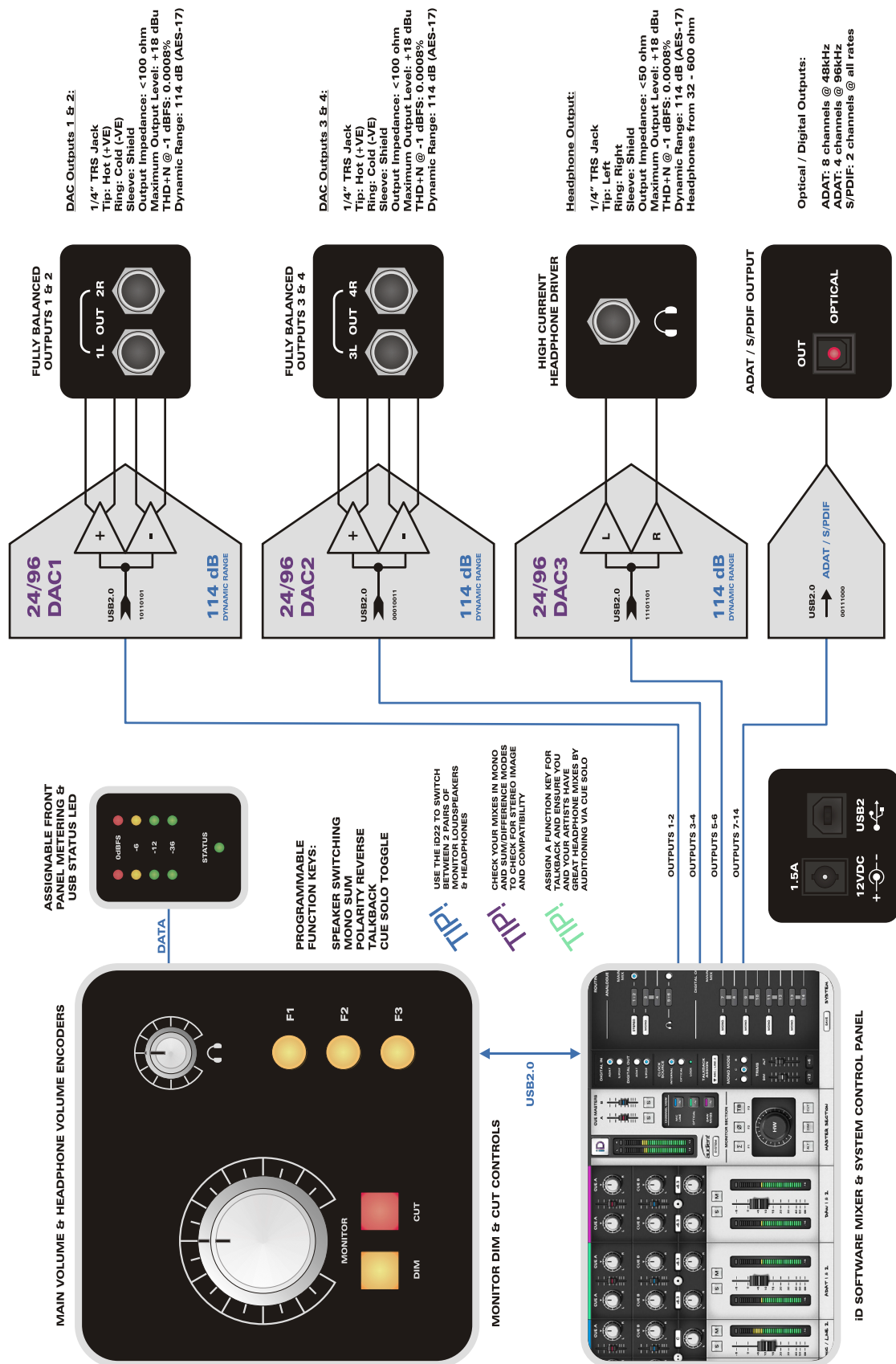

High Performance D/A Converters, High Current Headphone Amplifier & Optical Output Block Diagram

iD-

DAW

3

DAW.

- (1+2) -
- (S / PDIF ADAT) -
- DAW (Playback 1-6) -

DSP-
Cue



iD22

3

iD-

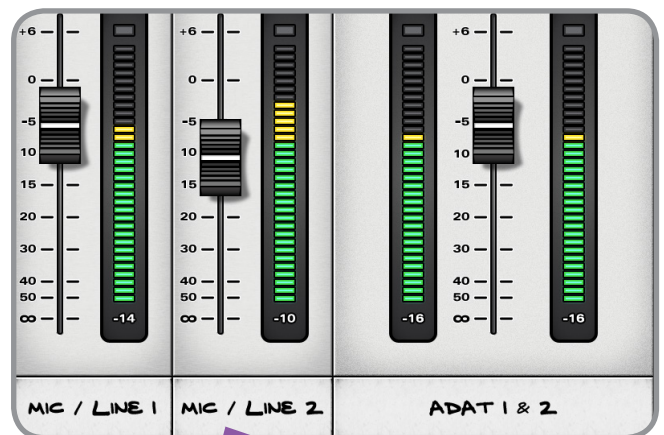

, MIC / LINE 1 KICK

(
:
(2)
2
S/PDIF 8
(4 > 48). ADAT



Cue A
 (0)
 ()
 0, Alt + click

Cue B
 (0)
 ()
 0, Alt + click

Solo Cut

Command (?) + click
 (Ctrl + click Windows) Solo,

Solo

Solo

Command (?) + click
 (Ctrl + click Windows) Solo, Solo

+6

0, Alt + click

66

Alt + click

iD-

-8

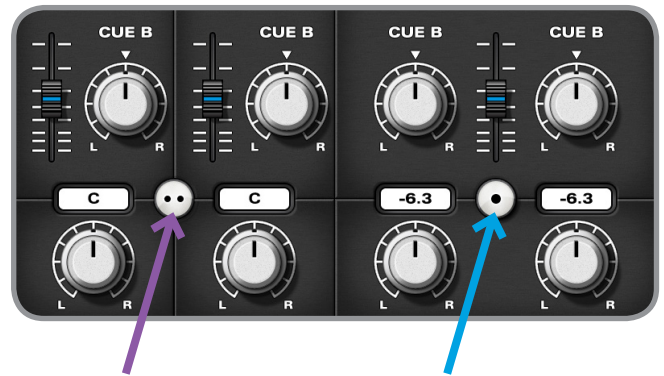

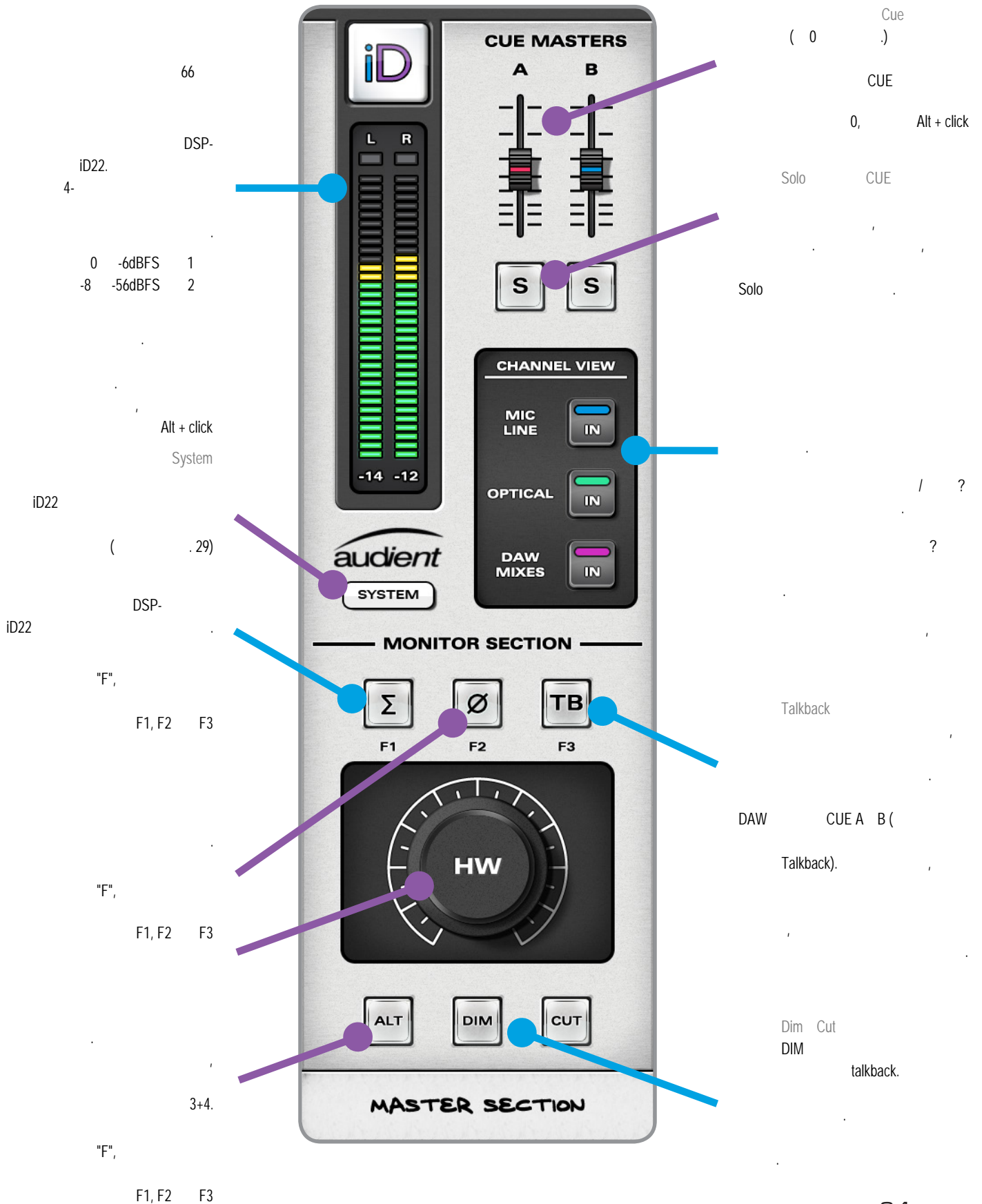

(iD22)

DSP-

(Analogue + DAW),
/ DAW.

Main Mix.

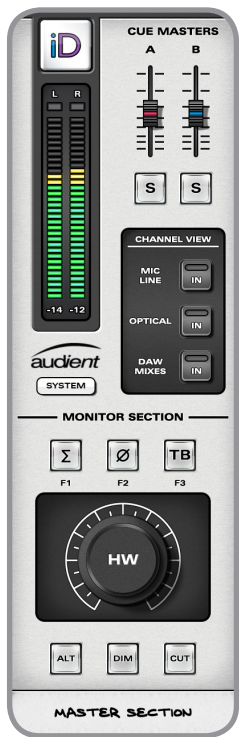

ASP880, ADAT

10

(.32)

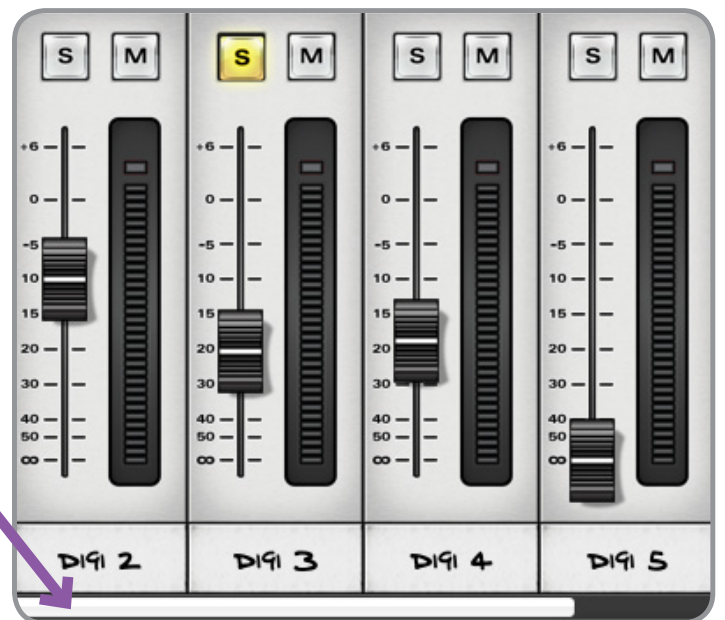

()

"F".

Σ

()

Mono Sum iD-

∅



ALT

L+R

L-R.

ALT SPK.

(L-R).

ADAT),
5+6.

(S/PDIF
3+4

(),

5+6

ALT

DSP.

Talkback -

28.

3+4.

SYSTEM,

Command(⌘) + 4 OSX, Ctrl + 4 Windows.

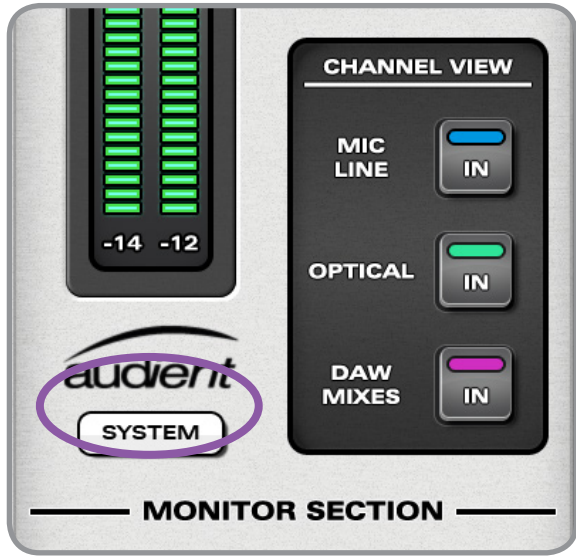

: ADAT
(8) S/PDIF (2).
ADAT 8- . 44,1 - 48
4- . 88,2 - 96
S/PDIF 2- .

: ADAT
(8) S/PDIF (2).
ADAT 8- . 44,1 - 48
4- . 88,2 - 96
S/PDIF 2- .

ASP880.

ASP800

DAW.

STATUS

Talkback

iD22 ()

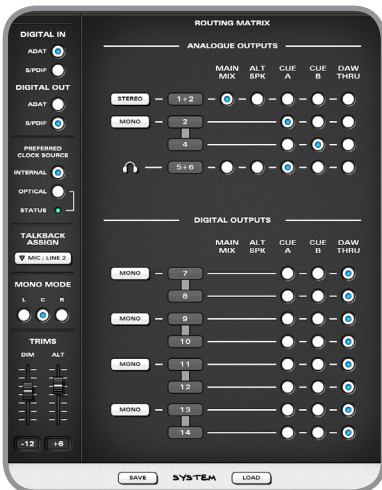

DIM ALT

DIM:

0 -30

ALT:

+/-15



Talkback

iD-

Talkback.



Talkback

iD22

2,

(ASP880)



iD22

Talkback

Talkback,

Cue A B,

Talkback.

Talkback
TB,

Talkback



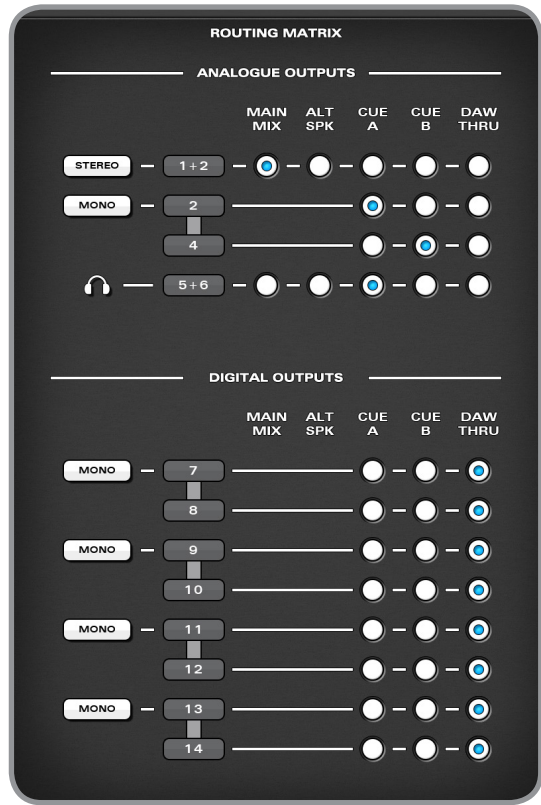
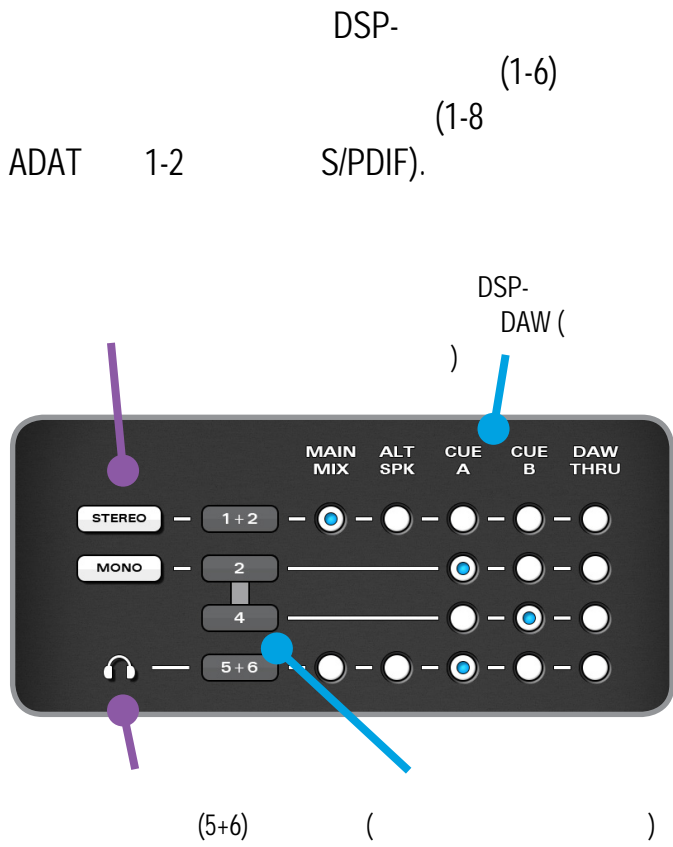

1+2

DSP-

Cue A B

iD-

Cue A

iD22 (5+6).

3+4

(3+4).

Cue B.

DAW THRU

iD-

C



- :
-
-
- (save): Command (⌘) + S
Ctrl + S (Windows)
- (load): Command (⌘) + O
Ctrl + O (Windows)

Load

X ().

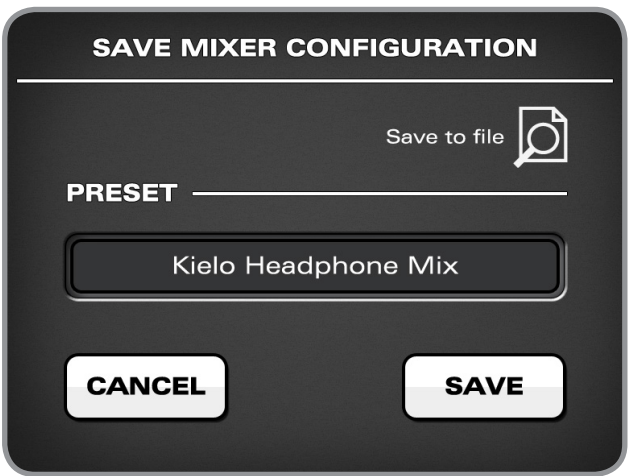

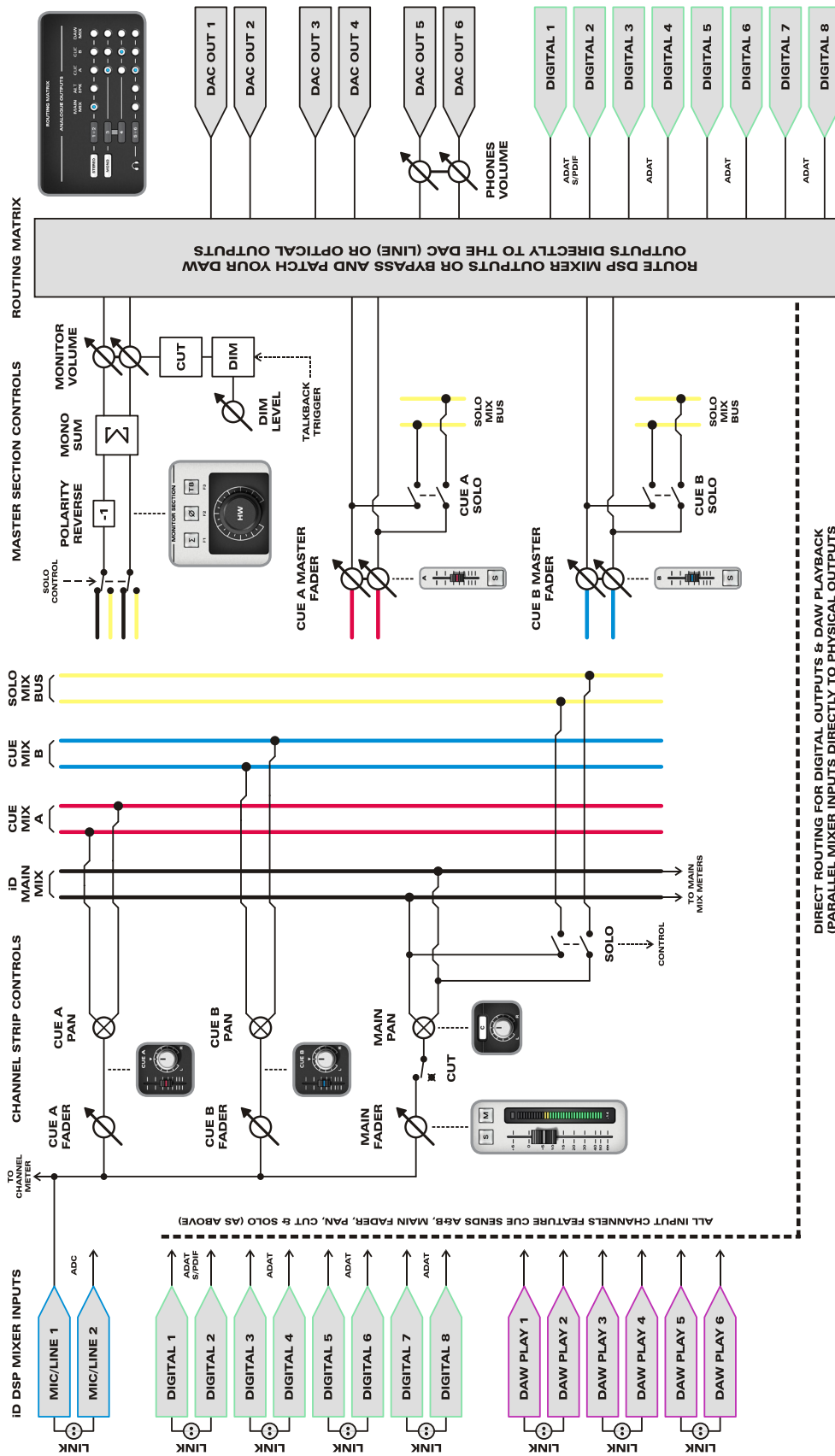

iD22 ONBOARD DSP MIXER APPLICATION BLOCK DIAGRAM

	Mac	Windows	
	Alt(⌘)+ Click	Alt + Click	(0)
	Alt (⌘)+ Click	Alt + Click	
Solo	Cmd (⌘)+ Click	Ctrl + Click	
			Solo
			Solo
			Solo
	Alt (⌘)+ Click	Alt + Click	
	Cmd(⌘)+ S	Ctrl + S	
	Cmd(⌘)+ O	Ctrl + O	
	Cmd(⌘)+ 1	Ctrl + 1	/
	Cmd(⌘)+ 2	Ctrl + 2	
	Cmd(⌘)+ 3	Ctrl + 3	DAW
	Cmd(⌘)+ 4	Ctrl + 4	Cmd

iD22
www.audient.com/iD22

Pro Tools

iD22

Pro Tools

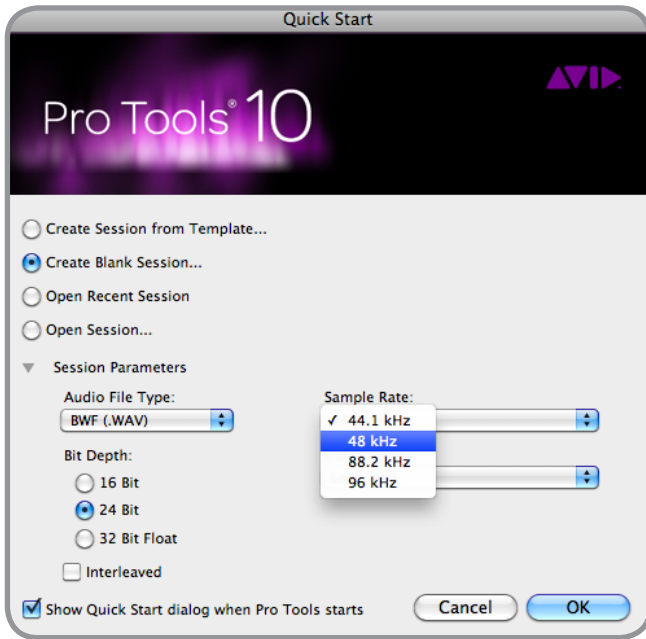
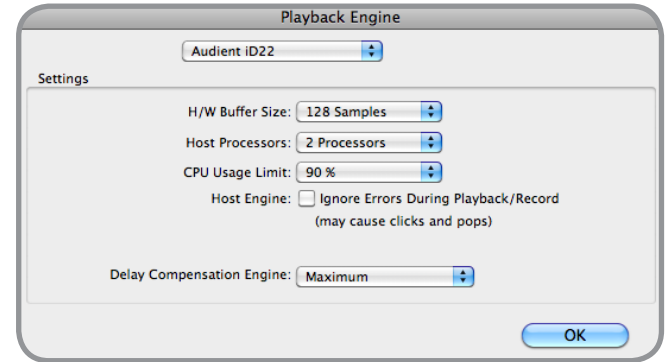

Setup > I/O... (

10

14

Pro Tools

iD22.

1-6

DAW DSP-

iD-

Pro Tools

Setup > Playback Engine...

iD22

Pro Tools

Pro Tools

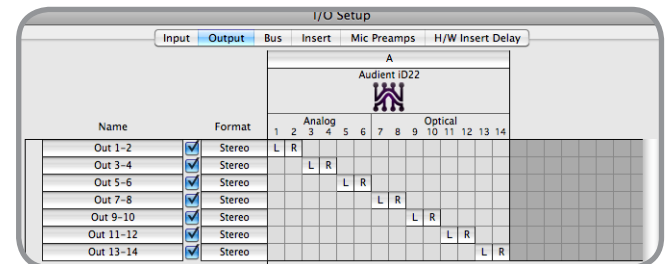
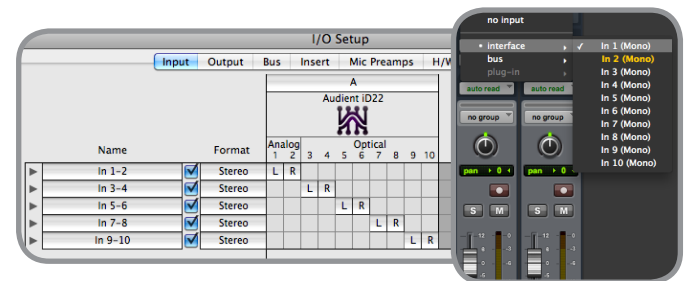

Logic Pro

iD22

DSP- iD22

Logic Pro

Logic,

Logic Pro > Preferences > Audio
(>)

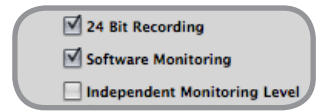
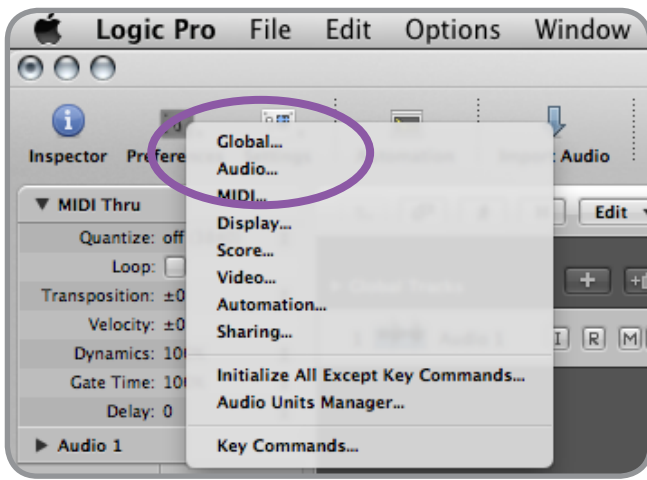

iD22

Logic.

10 14

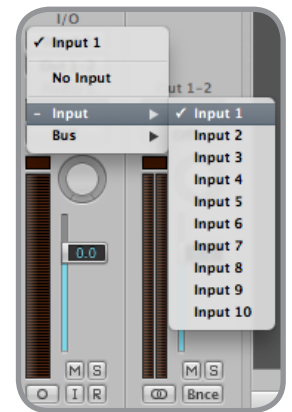

(I/O Labels)

iD22

(> 256)

Options > Audio > I/O Labels

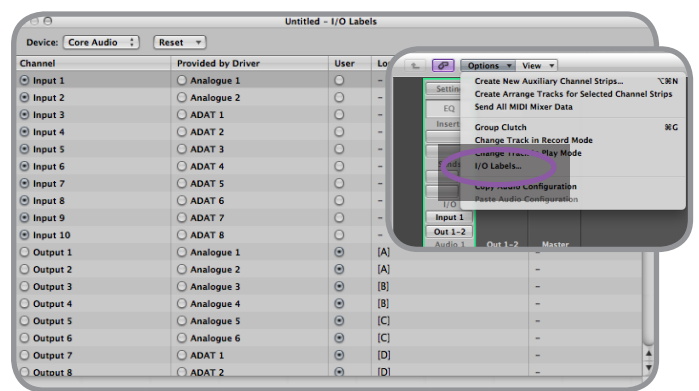
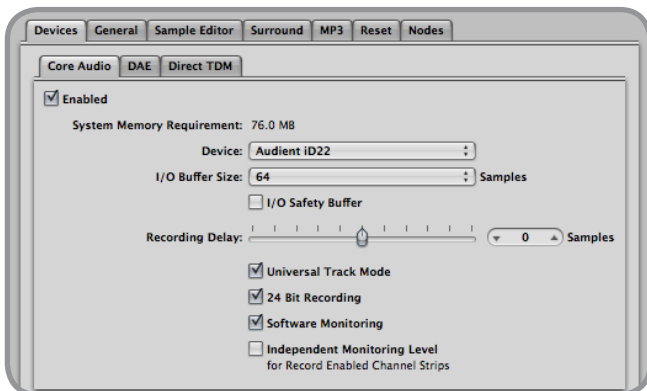

Logic Pro

iD22
ADAT S/PDIF,
Logic Pro

Settings > Audio > Sample Rate

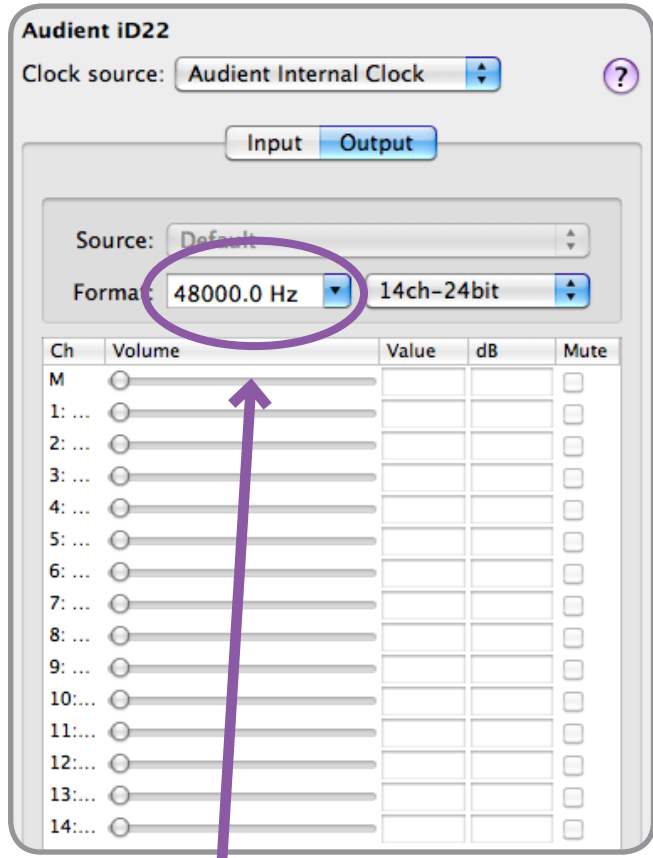
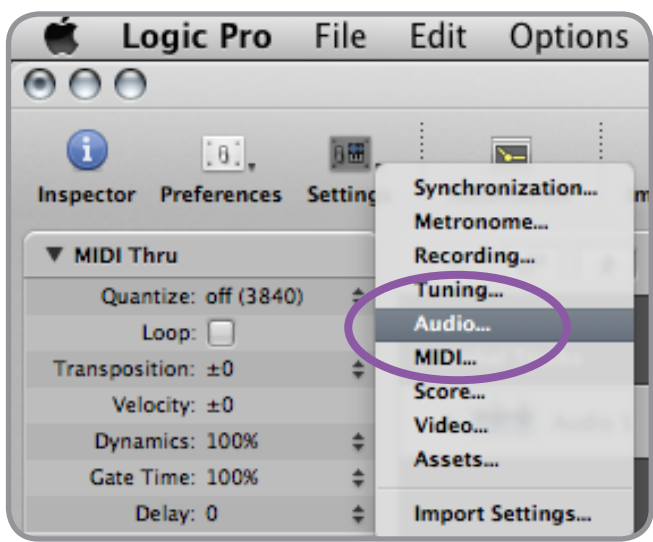

iD22
Sample Rate)
iD22

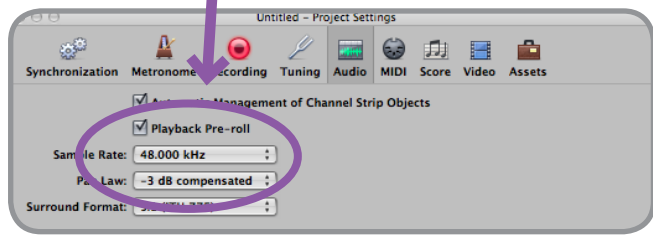

Logic Pro

Audio MIDI Setup.

Macintosh HD > Applications > Utilities

Cubase/Nuendo

Nuendo :
Cubase :
iD22 .6

Devices > Device Setup...

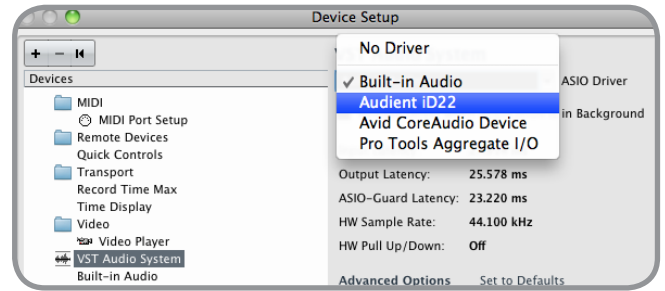

Cubase / Nuendo

iD22, Audient iD22

"Switch".



Audient iD22

Devices...

Device Setup ("VST Audio System".)

iD22,

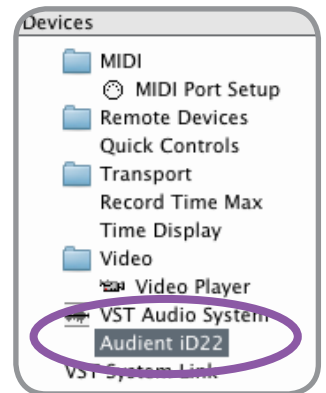

Externally Clocked,

ADAT / SPDIF.

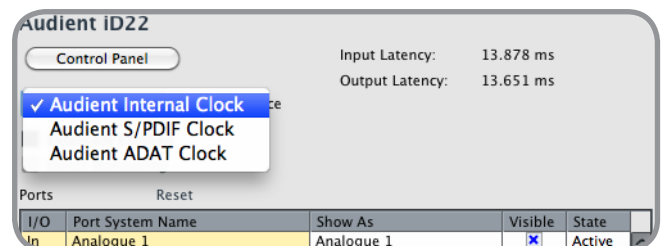
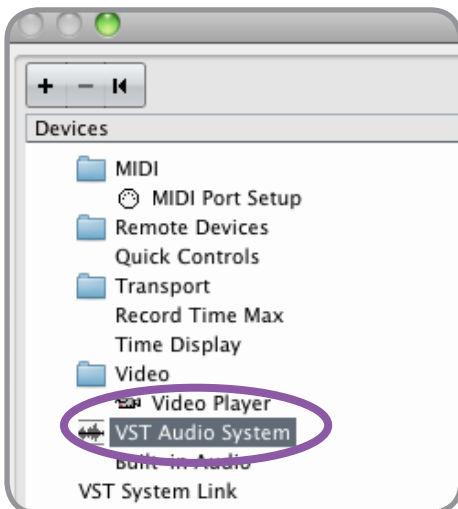

Cubase/Nuendo

(Control Panel) VST Device.
id-

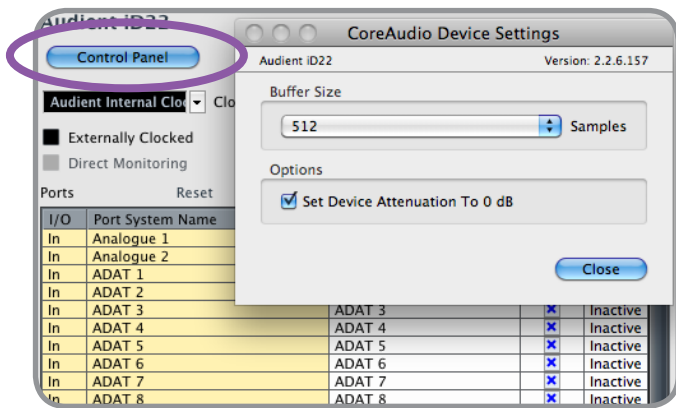

Nuendo Cubase

Monitors, Alt. Monitors, (, Main

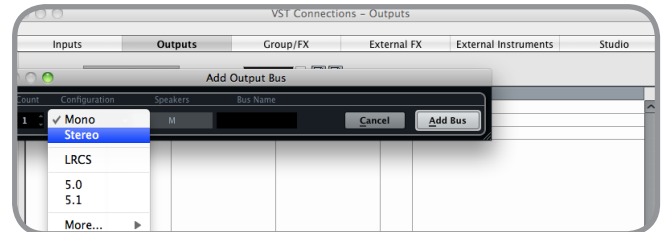
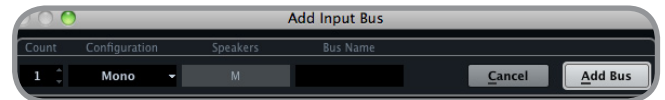
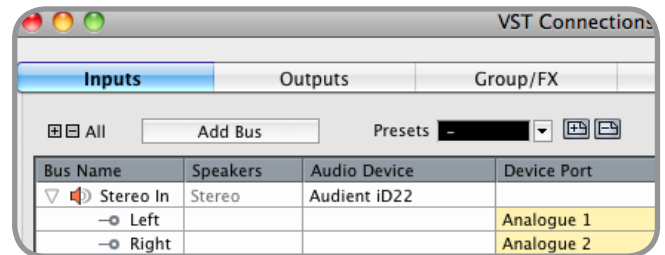

), VST Control Room.
Cubase/Nuendo

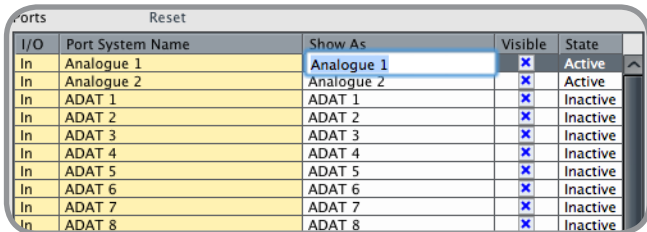

VST Device
VST:

Devices > VST Connections [F4]

Ableton Live

iD22

Ableton Live

Live > Preferences

Audio Preference

DSP-

iD22).

10

14

iD22.

Live

input and output config.

Ableton

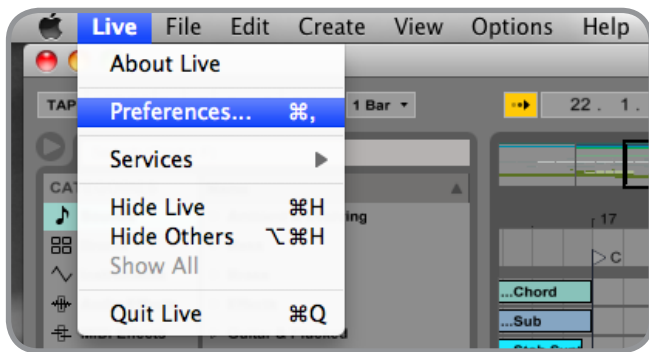

Audio

iD22

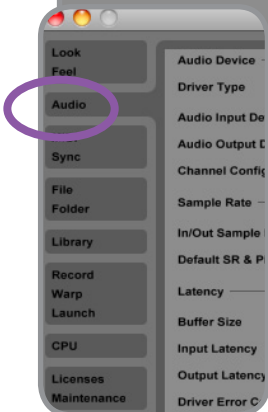
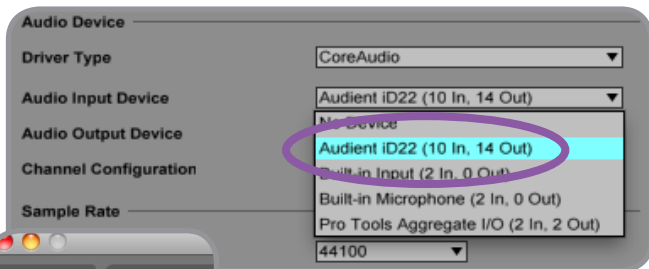

Ableton Live

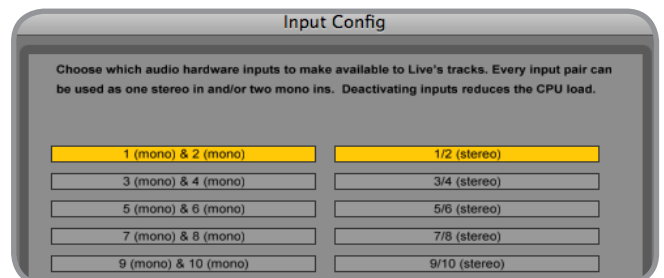
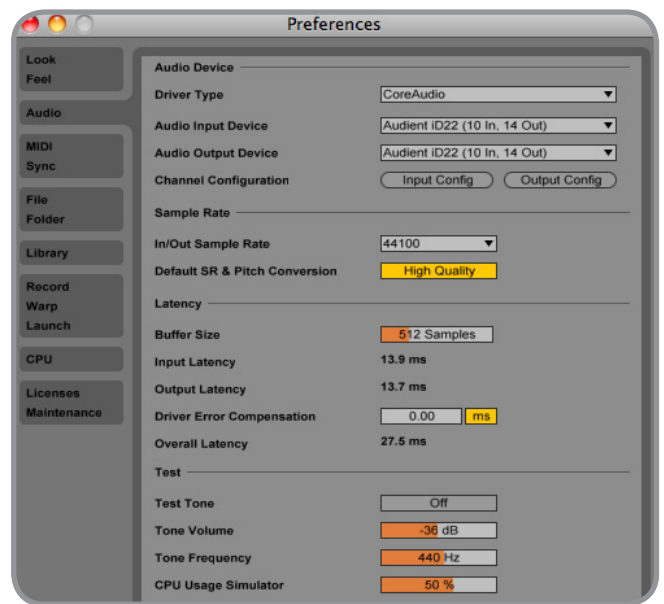

iD22.

+/- 0,5

12

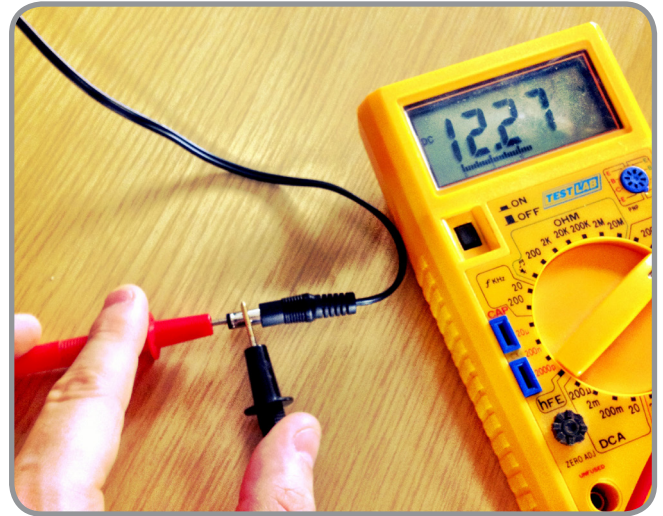

DAW iD-

DAW,

DAW 1+2.

iD22

DAW

iD22

iD22

USB

iD-

iD22.

iD22

iD-

System Preferences > Sound > Output Tab
> Audient iD22 [OSX]

Control Panel > Hardware and Sound >
Sound > Manage Audio Devices > Audient
iD22 [Windows]

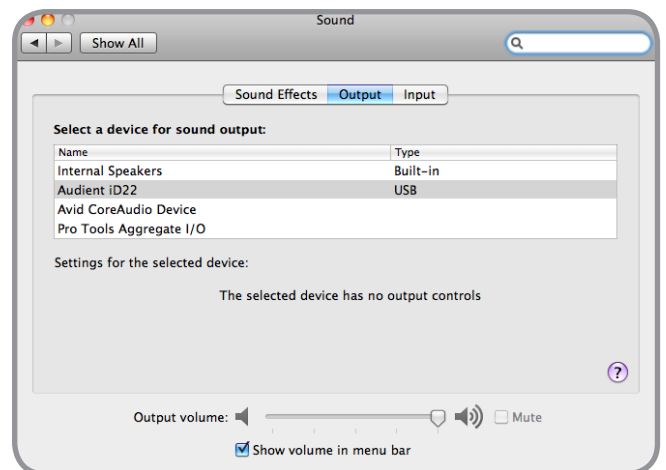

ProTools:

iD22
ADAT

Audio MIDI Setup OSX,

Macintosh HD > Applications > Utilities > Audio MIDI Setup

(Window Menu, Show Audio Window).

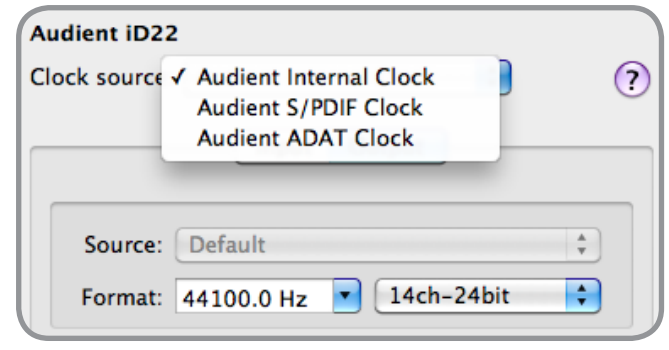
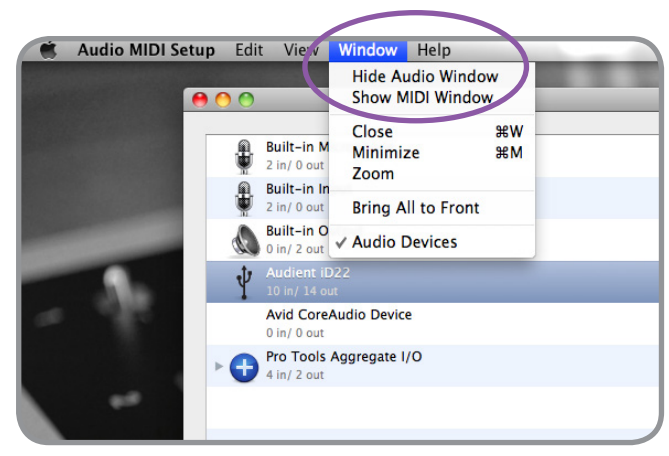

Windows

iD

iD22) ADAT S/PDIF

Format

ADAT

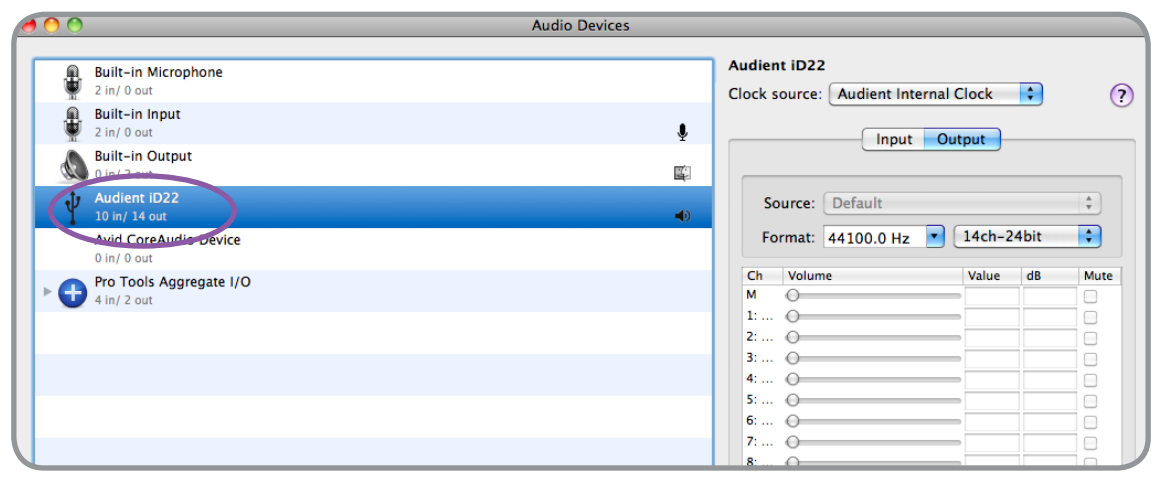

state.xml (

www.audient.com/support

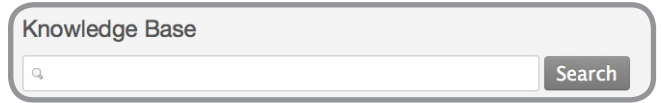

Macintosh HD > User > Library > Application Support > Audient > iD22 > state.xml

, Zendesk,

()

iD- ?
iD- ?
www.audient.com/iD22

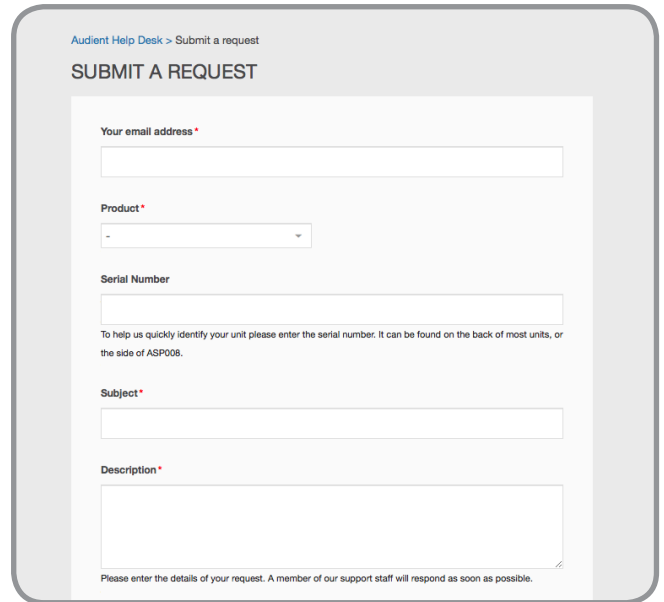

iD22

« »
« »

.8

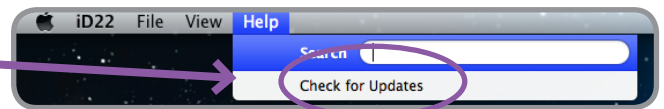



()

: -10 +60 (-10)
 : -20 +40 (-10)
 : 48 . +/-4 . 10 /
 : <-125dBu
 : >80 1
 : +22dBu (+32dBu)
 (): >3
 (): >10
 : +/-0,5 10 100
 : <-90dBu 1 10
 <0,0015% (-96dBu)
 / :
 :
 XLR: 2 (+) / 3 (-) / 1 ()
 1/4" TRS : (+), (-) ()
 DI- (2):
 ()
 DI- : -16 +54 (-10)
 : +16dBu (), +22dBu
 : 1
 : +/-0,5 10 50
 THD+N 0 dBu (1): <0,03% (-70)
 / : 93
 1/4" TS : (+) ()
 () :
 : +22dBu
 : <100
 1/4" TRS : (+), (-) ()
 :
 : 12 , ->1,5
 : +48
 +/15 DSP
 id22
 USB .

() :

(AES-17)

: +18dBu
 : 0dBFS = +18dBu
 : >10
 : +/-0,5 10 Fs/2
 : -100dBu 1 10
 THD+N -1dBFS (1) : <0,002% (-94)
 THD+N -6dBFS (1) : <0,0015% (-97)
 : 117
 : 120
 1/4" TRS : (+), (-) ()

(1-4):

(AES-17)

: +18dBu
 : 0dBFS = +18dBu
 : <100
 : +/-0,5 5 Fs/2
 : -100dBu 1 10
 THD+N -1dBFS (1) : <0,0008% (-101)
 : 110
 : 114
 1/4" TRS : (+), (-) ()

(5 6):

(AES-17)

: +18dBu
 : 0dBFS = +18dBu
 : <100
 : +/-0,5 5 Fs/2
 : -110dBu 1 10
 THD+N -1dBFS (1) : <0,0008% (-101)
 : 110
 : 114
 1/4" TRS : (+), (-) ()

/ :

ADAT 8 44,1 - 48
 ADAT 4 88,2 - 96
 STEREO S/PDIF 44,1 - 96

USB2.0 HIGH SPEED:

: 10
 (2 ,8)
 : 14
 (6 ,8)

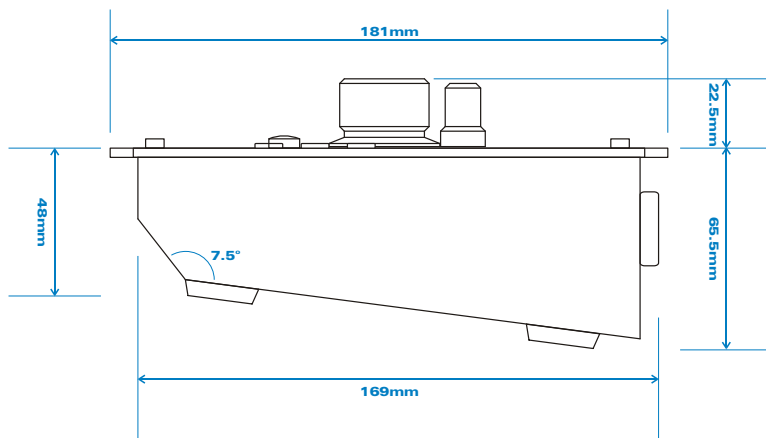
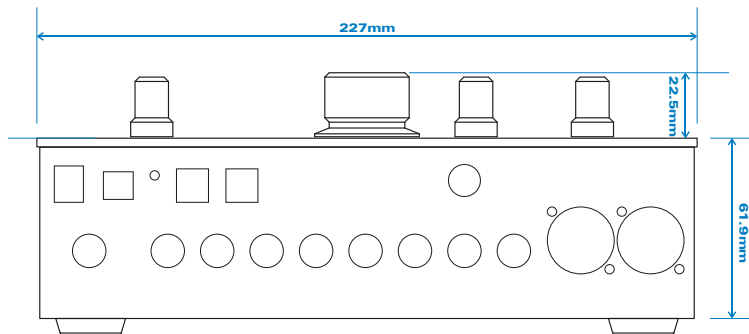
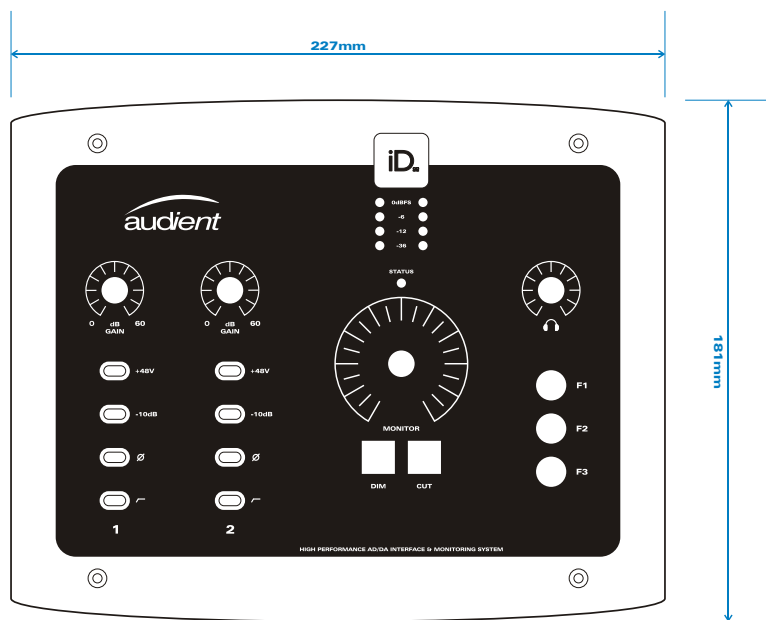

ID22

(12)

Audient

iD22,

Audient Ltd
Aspect House
Herriard
Hampshire
RG25 2PN
United Kingdom

Tel: 0044 1256 381944

www.audient.com

iD22

Audient Ltd.

iD22

Audient Ltd,

(RMA).

RMA
Audient

RMA,

: www.audient.com/support

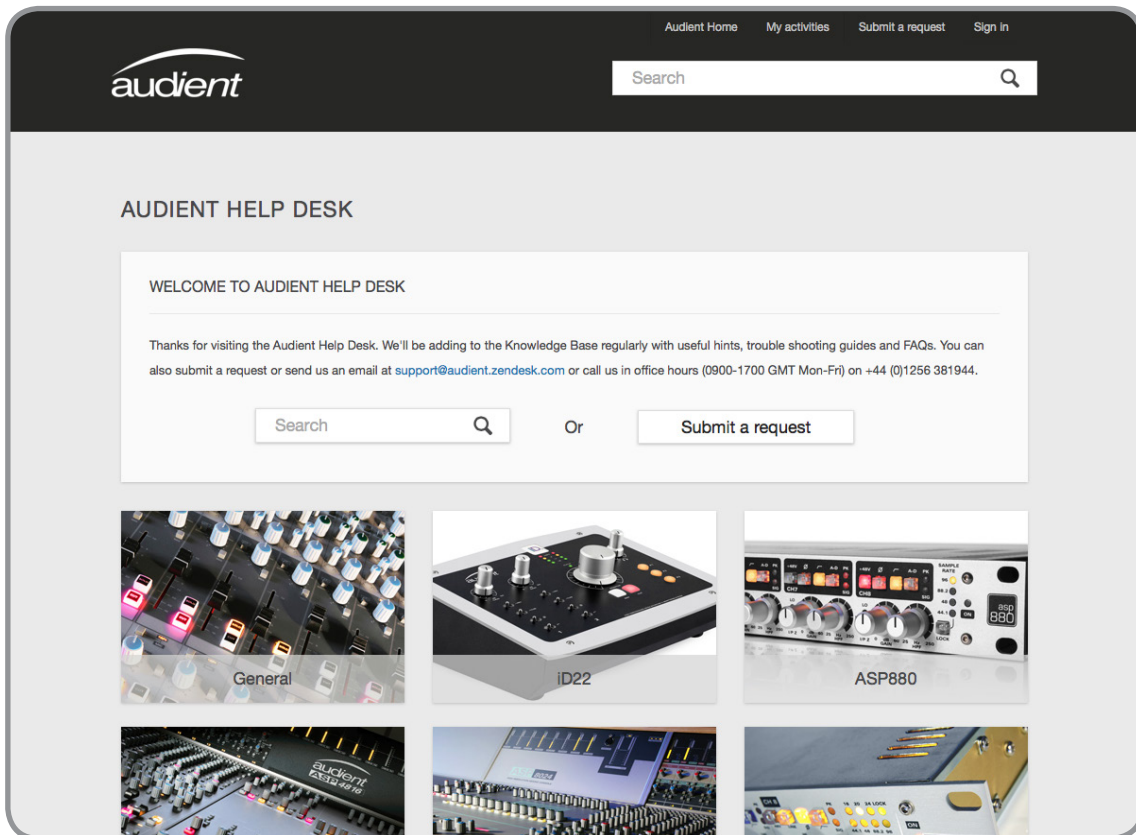

A	Amperes
ADAT	Alesis Digital Audio Tape
ADC	Analogue to Digital Converter
DAW	Digital Audio Workstation
ASP	Analogue Signal Processing
ALT	Alternative
CPU	Central Processing Unit
CUE	Artist Headphone Mix
DAC	Digital to Analogue Converter
dB	Decibel
dBu	Decibel referenced to 0.775Vrms = 0 dBu
dBFS	Decibel Full Scale
DC	Direct Current
D.I	Direct Injection (Instrument Input)
DoC	Declaration of Conformity
DSP	Digital Signal Processing
EQ	Equaliser
FAQ	Frequently Asked Questions
FCC	Federal Communications Commission
GB	Gigabyte
GUI	Graphical User Interface
HPF	High Pass Filter
HV	High Voltage
i/o	Input / Output
JFET	Junction Field Effect Transistor
LED	Light Emitting Diode
RoHS	Restriction of Hazardous Substances
RAM	Random Access Memory
S/PDIF	Sony Philips Digital Interconnect Format
THD+N	Total Harmonic Distortion + Noise
TRS	Tip Ring Sleeve (1/4" Jack Balanced)
TS	Tip Sleeve (1/4" Jack Unbalanced)
USB	Universal Serial Bus
V	Volts
XLR	Extra Live Return, Extremely Low Resistance, Canon X Series, Latching, Resilient Rubber Compound... or make up your own!



2015

1.8